

# EVISON User Manual for Processor HD101 & HD102



## Copyright ©

All rights reserved. No part of this document may be copied, reproduced or translated. It shall not otherwise be recorded, transmitted or stored in a retrieval system without the prior written consent of ROE.

## Warranty Policy

ROE Visual Co., Ltd. is pleased to offer a 2-year warranty on all standard products<sup>1</sup> against manufacturers' defects, covering parts and labors. ROE will provide both factory technical support and field service engineering when required during this period. Exclusions are listed below.

1. If replacement parts required, the customer will ship defective parts at their cost. ROE will ship replacement parts at our cost, during the warranty period.
2. In the case of special product<sup>2</sup> or custom systems<sup>3</sup>, each will be handled on an individual basis and specified as such in an agreement or contract.
3. After the expiration of the 2-year warranty, service/ repair charges will be the responsibility of the customer at standard industry rates.
4. The warranty will be voided in the case of:
  - a) Accidents or human error.
  - b) Any modifications, disassembly, repairs, maintenance or testing unauthorized by ROE.
  - c) The product serial number is broken (including SN/ESN/MEID/IMEI)
  - d) Gross negligence

## Contact Information

If you have any questions about this document, please feel free to contact with ROE technical service team.

### ROE China

ROE Visual Co., Ltd.  
No.3 Floor, Build 7, Zhong Yun Tai  
Technology Industrial Park,  
Baoan District, Shenzhen, China,  
518108  
Tel: +86-755-83924892  
Fax: +86-755-83924891  
service@roevisual.com

### ROE Europe

ROE Visual Europe BV  
Office: Zernikelaan 2a, 9351 VA Leek,  
The Netherlands  
Warehouse: Industriepark 9a, 9351 PA  
Leek, The Netherlands  
Tel: +31 (0) 50 211 0990  
europe@roevisual.com

### ROE America

ROE Visual US, Inc.  
9232 Eton Ave. Chatsworth, CA  
91311  
Tel: +1 747 229 9190  
usservice@roevisual.com

<sup>1</sup>ROE standard products are launched officially.

<sup>2</sup>Special products refer to the standard products are re-designed follow customer's requirement or completely design base upon customer's special demand.

<sup>3</sup>Customized system refers to products using special system which customer required.

## Contents

<b>Copyright © .....</b>	<b>2</b>
<b>Warranty Policy.....</b>	<b>2</b>
<b>Contact Information .....</b>	<b>2</b>
<b>1 Safety.....</b>	<b>5</b>
1.1 Level of Danger .....	5
1.2 Personal Protection .....	5
1.3 Installation Personnel .....	6
1.4 Safety Performance .....	6
<b>2 Sécurité.....</b>	<b>7</b>
2.1 Niveau de danger.....	7
2.2 Protection personnelle.....	7
2.3 Personnel d'installation.....	8
2.4 Performance de sécurité.....	8
<b>3 Introduction .....</b>	<b>9</b>
3.1 About Manual.....	9
3.2 About EVISION System .....	9
<b>4 General Information .....</b>	<b>9</b>
4.1 HD101.....	9
4.2 HD102.....	11
4.3 Basic Comparison of HD101 and HD102 .....	14
4.4 System Cabling Diagram .....	14
<b>5 Quick Start Guide.....</b>	<b>15</b>
5.1 PC-Processor Control Signal Cabling .....	15
5.2 Processor Output Cabling .....	15
5.3 Video Input Cabling.....	16
5.4 Power Cabling and Power On.....	16
5.5 Detect Sender Card (Processor) and Receiver Card.....	17
5.6 Select Output Port .....	17
5.7 Select Config. File .....	17
5.8 Adjust Tile QTY and Position .....	18
5.9 Mapping .....	18
5.10 Output Capacity.....	18
5.11 Test Patterns .....	19

5.12	Preview, Save Mapping, Save Setting .....	19
5.13	Disconnect PC.....	19
<b>6</b>	<b>Functions.....</b>	<b>20</b>
6.1	Video Loop.....	20
6.2	Multi-function.....	20
6.3	Tile Status in EVISION.....	20
6.4	Setting Export & Import.....	21
6.5	Individual Type Positioning .....	21
6.6	Current Gain .....	22
6.7	Tile Reset.....	22
6.8	Advanced Display Settings .....	23
6.9	Extra Functions on Setup .....	23
6.10	HDMI/DVI.....	25
6.11	EDID Set .....	25
6.12	Import New Tile types.....	25
6.13	Hot Backup .....	26
6.14	Multiple Processors Control.....	28
6.15	Multiple Tile Types Control.....	28
6.16	Edge Correction .....	29
6.17	Gamut Adjustment (Only HD102 supported).....	31
<b>7</b>	<b>Firmware Upgrade for HD102 Processor &amp; Panels.....</b>	<b>33</b>
7.1	HD102 processor firmware upgrade.....	33
7.2	Panel firmware upgrade .....	35
<b>8</b>	<b>Troubleshooting .....</b>	<b>36</b>
8.1	No sender detected while using Ethernet cable for control .....	36
8.2	LED screens didn't show the changes made on EVISION.....	36
<b>9</b>	<b>Appendix.....</b>	<b>37</b>
9.1	Accessories for HD102.....	37
9.2	Keyboard Shortcuts.....	39
9.3	IP Setup.....	39
9.4	Maximum Loading Capacity of One Output Port of HD102 .....	40
9.5	Menu Topology of HD102 .....	41
<b>10</b>	<b>Revision History.....</b>	<b>41</b>

## 1 Safety

### WARNING

Failure to read and understand the operator's manual or all safety signs could result in death or serious injury.

#### 1.1 Level of Danger

##### DANGER

Danger: Indicate(s) a hazardous situation which, if not avoided, WILL result in death or serious injury. But it should not be used for property damage hazards unless personal injury risk appropriate to these levels is also involved.

##### WARNING

Warning: Indicate(s) a hazardous situation which, if not avoided, COULD result in death or serious injury. But it should not be used for property damage hazards unless personal injury risk appropriate to these levels is also involved.

##### CAUTION

Caution: Indicates(s) a hazardous situation which, if not avoided, could result in minor moderate injury, or result in property damage.

##### NOTICE

Notice: Preferred to address practice NOT related to personal injury, but maybe to indicate a hazardous situation which, if not avoided, could result in property damage.

#### 1.2 Personal Protection



DANGER: Risk of electric shock



WARNING: Ensure you understand and follow all safety guidelines, instructions, warnings, and cautions mentioned in this manual.



WARNING: Be aware of flammable materials



WARNING: Read this manual before the installation and keep this manual for future reference.



WARNING: Be careful of hazardous emission to vision. The fixture emits high levels of visible and invisible light radiation which can be hazardous to vision. Use proper vision protection when working near fixtures.



WARNING: Mind your fingers when working with heavy loads.

---



WARNING: Pay attention to hot surfaces.

---

### 1.3 Installation Personnel

The installation must be performed by authorized and qualified technical personnel only.

### 1.4 Safety Performance

- The product is only for professional use.
- Please read the User Manual carefully and understand all safety information mentioned before installing, powering, operating or servicing the product.
- Please follow all instructions of the User Manual during installing, powering, operating or servicing the product.
- The installation should be performed after you are thoroughly familiar with all safety guidelines, instructions, warnings, and cautions. Otherwise, it may increase risks of hazards and injury to the user.
- Please install and/or keep this product away from flammable materials, heat sources, water, high-power electrical devices, and dangerous chemicals.
- Please use and/or store this product at proper temperature and humidity.
- Please earth this product against the risk of electric shock.
- Please make sure power and data cables are in a sound condition.
- Please do not use the product near the sea and/or other places with a corrosive environment.
- The installation must be performed by authorized and qualified technical personnel only.

## 2 Sécurité

### ATTENTION

Si vous ne lisez pas et ne comprenez pas le manuel d'utilisation ou tous les signes de sécurité, vous risqueriez des blessures graves, voire mortelles.

#### 2.1 Niveau de danger

<b>DANGER</b>	Danger: Indique une situation dangereuse qui, si elle n'est pas évitée, entraînera la mort ou des blessures graves. Cependant, il ne doit pas être utilisé pour des dommages matériels, sauf si un risque de préjudice personnel adapté à ces niveaux est également impliqué.
<b>ATTENTION</b>	Avertissement: Indiquez une situation dangereuse qui, si elle n'est pas évitée, POURRAIT causer des blessures graves, voire mortelles. Cependant, il ne doit pas être utilisé pour des dommages matériels, sauf si un risque de préjudice personnel adapté à ces niveaux est également impliqué.
<b>MISE EN GARDE</b>	Attention: indique une situation dangereuse qui, si elle n'est pas évitée, pourrait entraîner des blessures légères ou modérées, ou des dommages matériels.
<b>REMARQUER</b>	REMARQUER: Il est préférable d'aborder des pratiques NON liées à des blessures corporelles, mais plutôt d'indiquer une situation dangereuse qui, si elle n'est pas évitée, pourrait entraîner des dommages matériels.

#### 2.2 Protection personnelle



DANGER: Risque de choc électrique



AVERTISSEMENT: assurez-vous de comprendre et de respecter toutes les consignes de sécurité, instructions, avertissements et précautions mentionnés dans ce manuel.



AVERTISSEMENT: Soyez conscient des matériaux inflammables



AVERTISSEMENT: lisez ce manuel avant l'installation et conservez-le pour référence ultérieure.

**La dernière version de ce document est disponible sur le site Web du RE: [www.roevisual.com](http://www.roevisual.com)**



AVERTISSEMENT: Faites attention aux émissions dangereuses pour la vue. L'appareil émet des niveaux élevés de rayonnement lumineux visible et invisible pouvant être dangereux pour la vision. Utilisez une protection de la vue appropriée lorsque vous travaillez près de l'appareil.



AVERTISSEMENT: Faites attention à vos doigts lorsque vous travaillez avec de lourdes charges.

---



AVERTISSEMENT: Faites attention aux surfaces chaudes.

---

### 2.3 Personnel d'installation

L'installation doit être effectuée uniquement par un personnel technique autorisé et qualifié.

### 2.4 Performance de sécurité

- Le produit est uniquement destiné à un usage professionnel.
- Veuillez lire attentivement le manuel d'utilisation et comprendre toutes les informations de sécurité mentionnées avant d'installer, de mettre en marche, d'utiliser ou de réparer le produit.
- Veuillez suivre toutes les instructions du manuel d'utilisation lors de l'installation, de la mise sous tension, de l'utilisation ou de la maintenance du produit.
- L'installation doit être effectuée une fois que vous êtes familiarisé avec toutes les consignes de sécurité, les instructions, les avertissements et les précautions. Sinon, cela pourrait augmenter les risques de danger et de blessure pour l'utilisateur.
- Veuillez installer et / ou garder ce produit à l'écart de matières inflammables, de sources de chaleur, d'eau, d'appareils électriques à haute puissance et de produits chimiques dangereux.
- Veuillez utiliser et / ou stocker ce produit à une température et à une humidité appropriées.
- Veuillez mettre ce produit à la terre contre le risque de choc électrique.
- Assurez-vous que les câbles d'alimentation et de données sont en bon état.
- Veuillez ne pas utiliser le produit à proximité de la mer et / ou d'autres lieux soumis à un environnement corrosif.
- L'installation doit être effectuée par du personnel technique autorisé et qualifié.



### 3 Introduction

#### 3.1 About Manual

This manual provides introductions on the operations of the EVISION control system, for Processor HD101 & HD102. A read-through of this manual before operations is strongly recommended.

#### 3.2 About EVISION System

EVISION establishes networks connecting processors, receiving cards and LED panels, providing fresher-friendly UI and experience.

### 4 General Information

#### 4.1 HD101

##### 4.1.1 Front panel

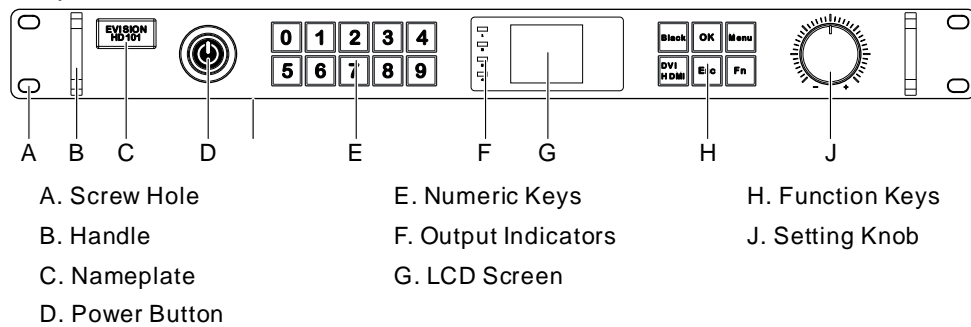

Figure 4-1. HD101 front

##### 4.1.2 Rear panel

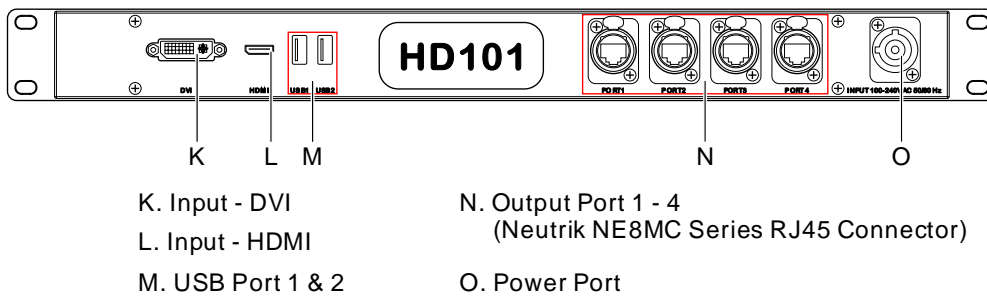

Figure 4-2. HD101 rear

##### 4.1.3 Dimensions

Dimension: L485 x W240 x H45mm, 1U.

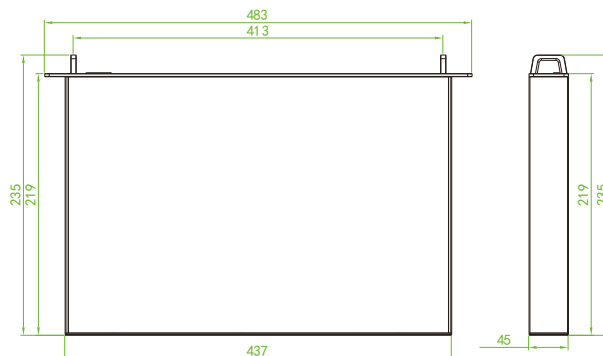

Figure 4-3. HD101 dimensions

## 4.1.4 Software and Product Support Information

Table 4-1. Software &amp; products supported by HD101

Software & Products	Version
EVISION	Version 3.6 or higher recommended.
LEDUpgrade	Version 1.20 or higher, works on both FPGA & ARM
Receiving Cards	5A, i5A, i5, i6, iM9 (11.13, multifunction card)

## 4.1.5 Specification of HD101

Table 4-2. Specification for HD101

Item		Figure		
Storage Temperature		-35~70°C		
Storage Humidity		25~50%		
Operating Temperature		-20~40°C		
Operating Humidity		10~90%		
Power In		100-240V AC 50/60Hz		
Dimension		L485 x W240 x H45mm, 1U		
Net Weight (Processor Only)		2.3kg		
Nominal pixel capacity		~2.1M pixels (Equivalent to 1920 px x 1080 px @60 Hz)		
Input	Input Ports	DVI * 1, HDMI * 1		
	DVI In/Loop	Max. Input/Loop Width	2560 px (2560 x 810 @60 Hz)	
		Max. Input/Loop Height	1600 px (1296 x 1600 @60 Hz)	
		DVI-I (Dual-Link, Female). VESA Standard (1080p input supported)		
	HDMI In/Loop	Max. Input/Loop Width	2560 px (2560 x 810 @60 Hz)	
		Max. Input/Loop Height	1600 px (1296 x 1600 @60 Hz)	
HDMI1.4 - Type A. EIA/CEA-861 Standard. HDCP1.4 supported (HDMI In Only).				
Output	Output Ports	Gigabit Ethernet port * 4, available for Neutrik NE8MC RJ45 connector or RJ45 terminator		
	Max. Output Per Port	655,000 px @60 Hz		
	Max. Output Width	2,560 px		
	Max. Output Height	1,600 px		
	Ethernet Output		Regular Mode	Low Latency Enabled
		Max. Output	655,000 px	
		Max. Width	2,560 px	512 px
Max. Height	1,600 px			
Control	USB	USB 2.0 Type A (female) * 2, for control & processors cascade;		

## 4.2 HD102

### 4.2.1 Front panel

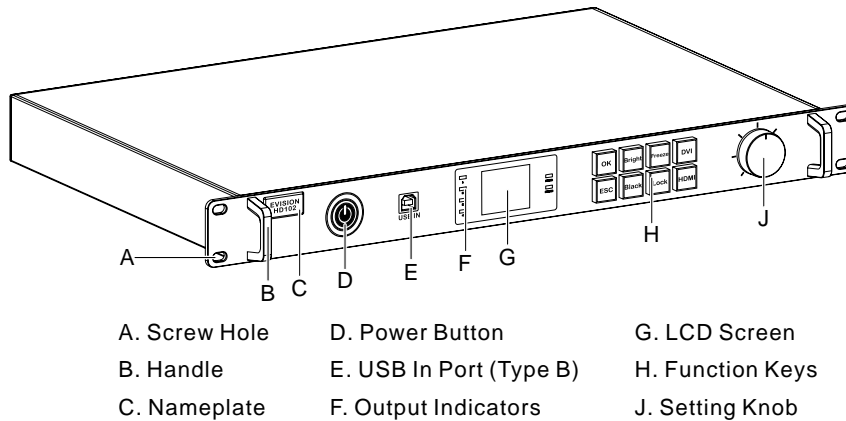

Figure 4-4. HD102 front

### 4.2.2 Rear panel

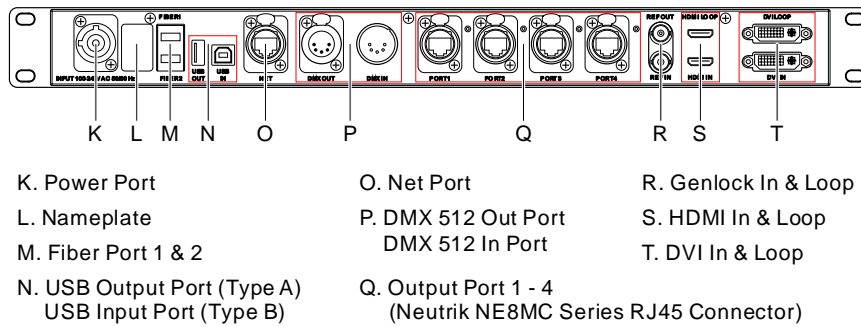

Figure 4-5. HD102 rear

### 4.2.3 Dimensions

Dimension: L485 x W320 x H45mm, 1U.

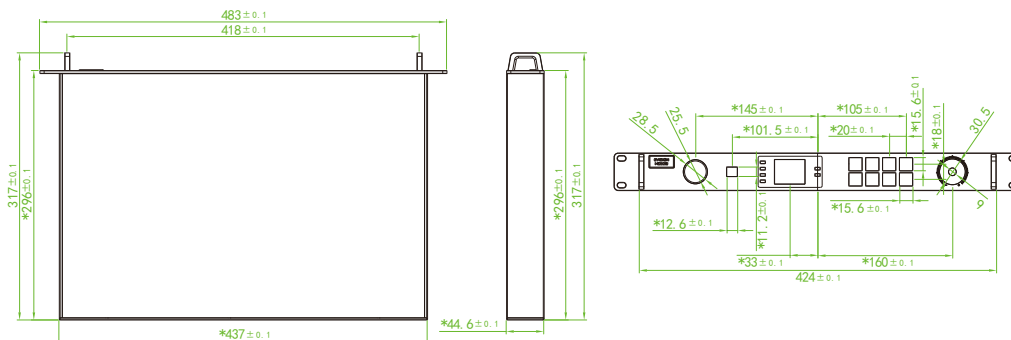

Figure 4-6. HD102 dimensions

### 4.2.4 Software and Product Support Information

Table 4-3. Software & products supported by HD102

Software & Products	Version
EVISION	Version 3.6 or higher recommended.
LEDUpgrade	Version 1.20 or higher, works on both FPGA & ARM
Receiving Cards	5A, i5A, i5, i6, iM9 (11.13, multifunction card)

## 4.2.5 Specification of HD102

Table 4-4. Specification for HD102

Item		Figure		
Storage Temperature		-35~70°C		
Storage Humidity		25~50%		
Operating Temperature		-20~40°C -20~60°C		
Operating Humidity		10~90%		
Power In		100-240V AC 50/60Hz		
Dimension		L485 x W320 x H45mm, 1U		
Net Weight (Processor Only)		3.2kg		
Gross Weight		5.1kg		
Nominal pixel capacity		~2.3M pixels (Equivalent to 1920 px x 1200 px @60 Hz)		
Input	Input Ports	DVI * 1, HDMI * 1		
	DVI In/Loop	Max. Input/Loop Width	4095 px (4095 x 562 @60 Hz)	
		Max. Input/Loop Height	1600 px (1440 x 1600 @60 Hz)	
		DVI-I (Dual-Link, Female). VESA Standard (1080p input supported)		
	HDMI In/Loop	Max. Input/Loop Width	4095 px (4095 x 562 @60 Hz)	
		Max. Input/Loop Height	1600 px (1440 x 1600 @60 Hz)	
EIA/CEA-861 Standard. HDMI1.4 - Type-A. HDCP1.4 supported (HDMI In Only).				
Output	Output Ports	Gigabit Ethernet port * 4, available for Neutrik NE8MC RJ45 connector or RJ45 terminator		
	Max. Output Per Port	655,000 px @60 Hz		
	Max. Output Width	DVI Input	HDMI Input	
		4095 px	4,095 px	
	Max. Output Height	DVI Input & HDMI Input		
		1,600 px		
	Ethernet Output		Regular Mode	Low Latency Enabled
		Max. Output	655,000 px @60 Hz	
		Max. Width	4,095 px	512 px
		Max. Height	1,600 px	
Fiber Output	2.5G single-mode fiber * 2, LC connector (transceiver module needed). Max. distance for 15km.			
Control	USB	USB 2.0 Type B (female) * 2, for PC-processor control; USB 2.0 Type A (female) * 1, for processors cascade.		
	Network Port	Fast Ethernet port (100Mbit)		
	DMX	DMX512, XLR5 Connectors		
	Genlock	Genlock In/Loop, BNC Connectors. Tri-level Sync.		

4.2.6 Packing List

Table 4-5. Items in HD102 package





#	Parts	QTY	Remarks
1	Processor HD102	1	NA
2	Power Input Cable	1	CN / US / EU Standard
3	User Manual for EVISION Control System	1	
4	USB Cable	1	Type A male-Type B male, 1.5m
 <p>#1 Processor HD102</p>		 <p>#2 Power Input Cable</p>	
 <p>#3 User Manual for EVISION Control System</p>		 <p>#4 USB Cable</p>	



Figure 4-7. Package of HD102

### 4.3 Basic Comparison of HD101 and HD102

Table 4-6. HD102 & HD101 comparison

		HD101	HD102
Video Input/Loop Ports	DVI In	YES	YES
	DVI Loop	NO	YES
	DVI Max. Input/Loop Width	2560 px (2560 x 810 @60 Hz)	3840 px (3840 x 540 @60 Hz)
	DVI Max. Input/Loop Height	1600 px (1296 x 1600 @60 Hz)	
	HDMI In	YES	YES
	HDMI Loop	NO	YES
	HDMI Max. Input/Loop Width	2560 px (2560 x 810 @60 Hz)	4095 px (4095 x 506 @60 Hz)
	HDMI Max. Input/Loop Height	1600 px (1296 x 1600 @60 Hz)	
Output Ports	Ethernet	Gigabit Ethernet*4 (RJ45, Cat5e & Cat6 supported)	
	Max. Output Width	2,560 px	4,095 px
	Max. Output Height	1,600 pixels	
	Fiber	NO	YES
Control Ports	USB	Type A female*2 (USB In & Out)	Type B female*2 (USB In), Type A female*1 (USB Out)
	Ethernet	NO	Fast Ethernet*1
	DMX	NO	DMX 512 In & Out
	Genlock	NO	Ref. In & Out
For the specification of HD101, please refer to page <a href="#">10, 4.1.5 Specification of HD101</a> .			
For the specification of HD102, please refer to page <a href="#">12, 4.2.5 Specification of HD102</a> .			

### 4.4 System Cabling Diagram

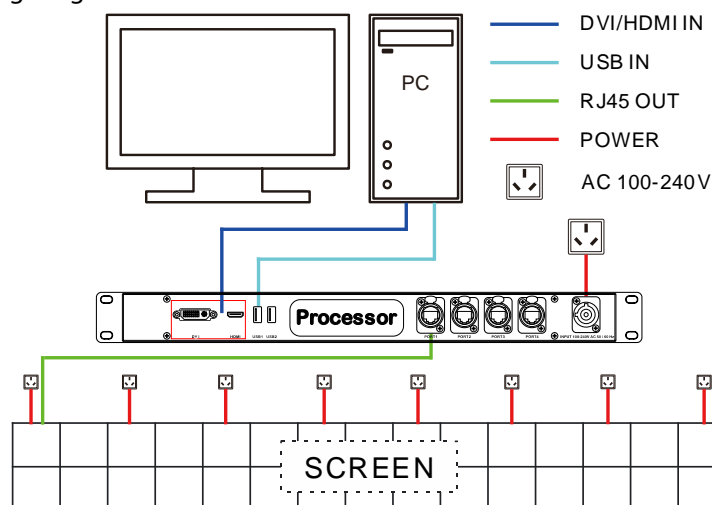

Figure 4-8. System cabling diagram

## 5 Quick Start Guide

### 5.1 PC-Processor Control Signal Cabling

Connect the processor with the PC, using either USB cables (USB type A, male – type B, male) or Ethernet cables (fast Ethernet).

**NOTICE**

If using Ethernet cable for control, please refer to page [39, 9.3 IP Setup](#) before further steps.

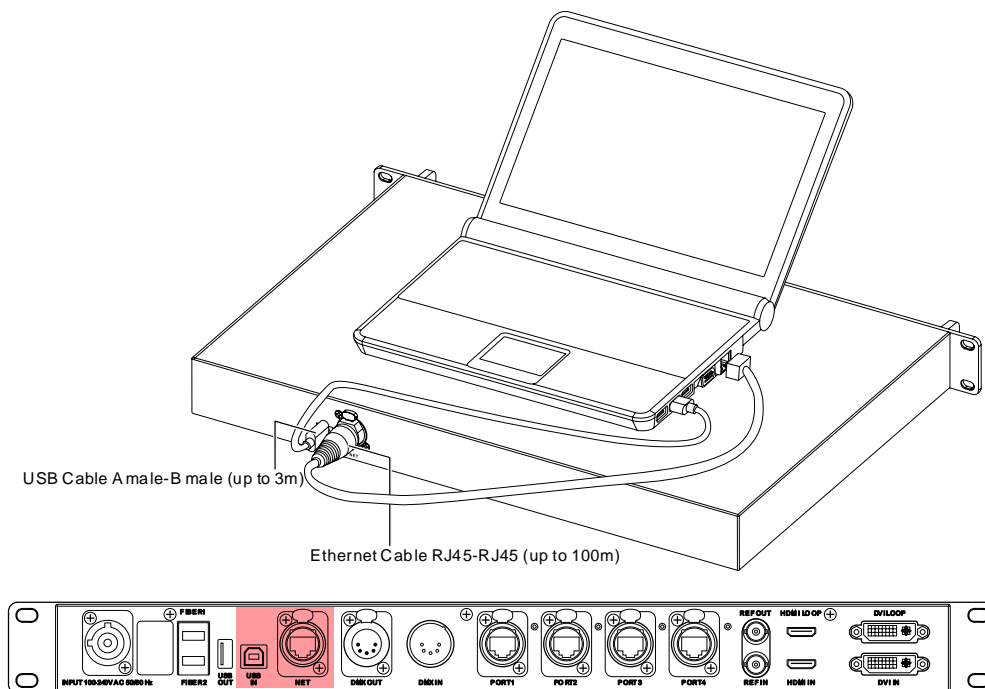

Figure 5-1. PC to processor connection

### 5.2 Processor Output Cabling

Connect the processor with the LED tiles, using Gigabit Ethernet cables (Cat5e or Cat6).

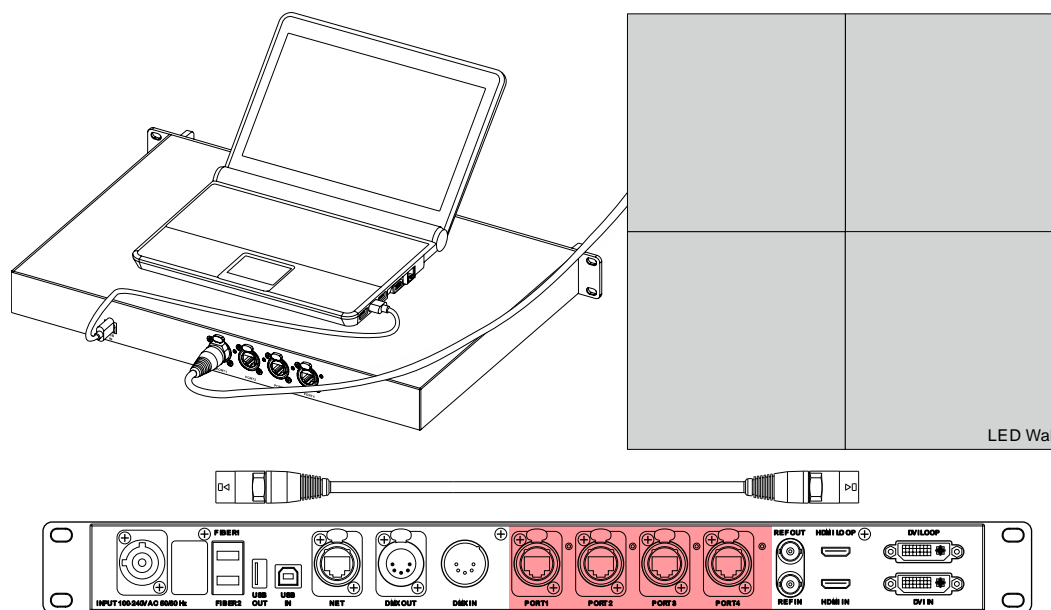

Figure 5-2. Processor to LED connection

### 5.3 Video Input Cabling

Connect the processor with the video source, using DVI cable (DVI-I, Dual Link, Female) or HDMI cable (HDMI type A, female).

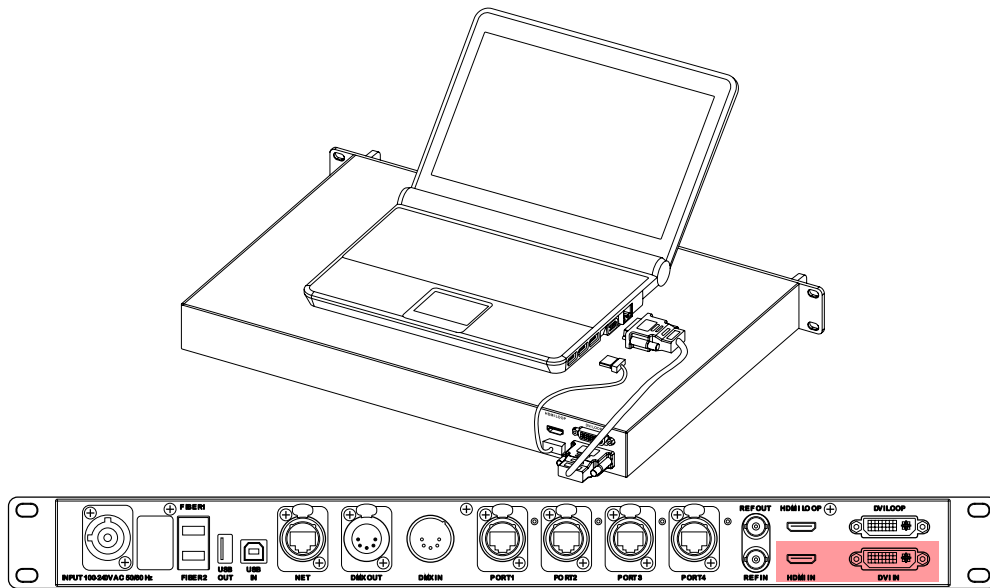

Figure 5-3. Processor video input

### 5.4 Power Cabling and Power On

Connect the processor with the power source, and turn on the processor, LED tiles.

**WARNING** Make sure the power cable is correctly connected before turning the power on.

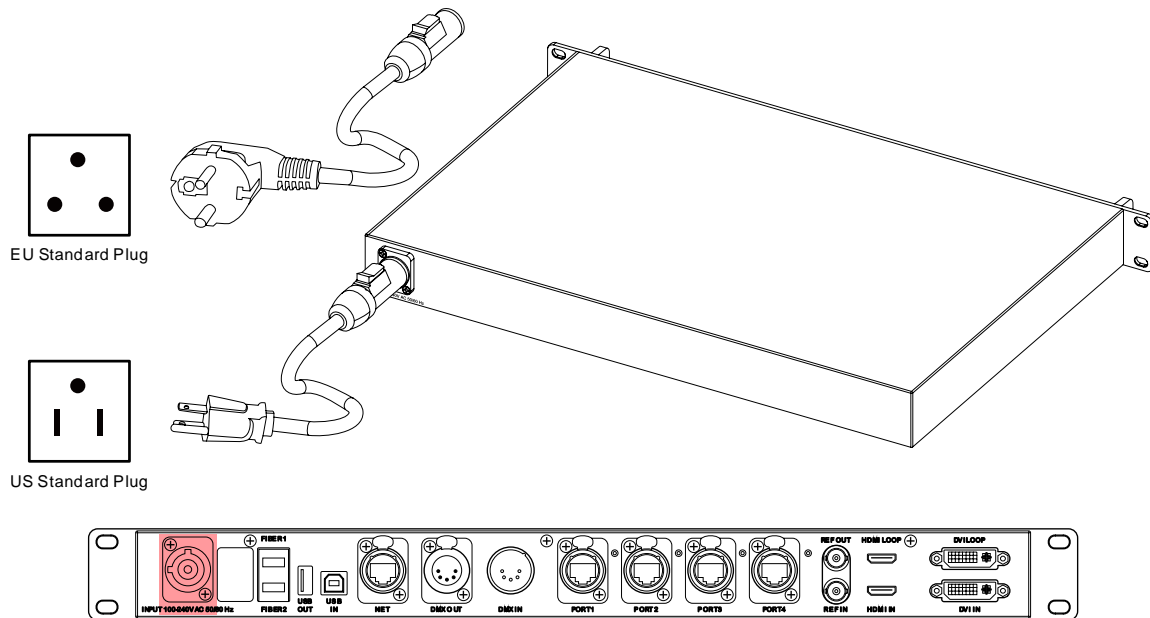

Figure 5-4. Processor power cabling



### 5.5 Detect Sender Card (Processor) and Receiver Card

Click the **Detect Sender Card** button to establish a connection between PC and processor.

Click the **Detect Receiver Card** button to establish connections between a processor and tiles.

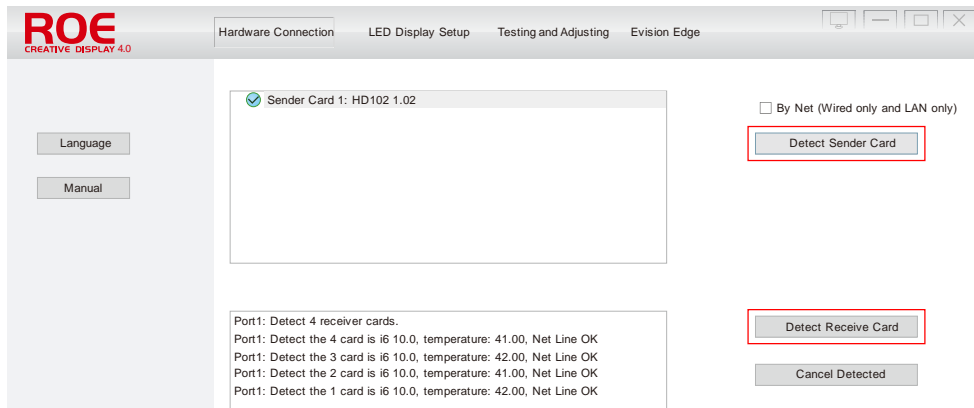

Figure 5-5. EVISION hardware connection

### 5.6 Select Output Port

Select the output port based on physical cabling.



Figure 5-6. Output ports

### 5.7 Select Config. File

Select the config file based on physical tiles connected.

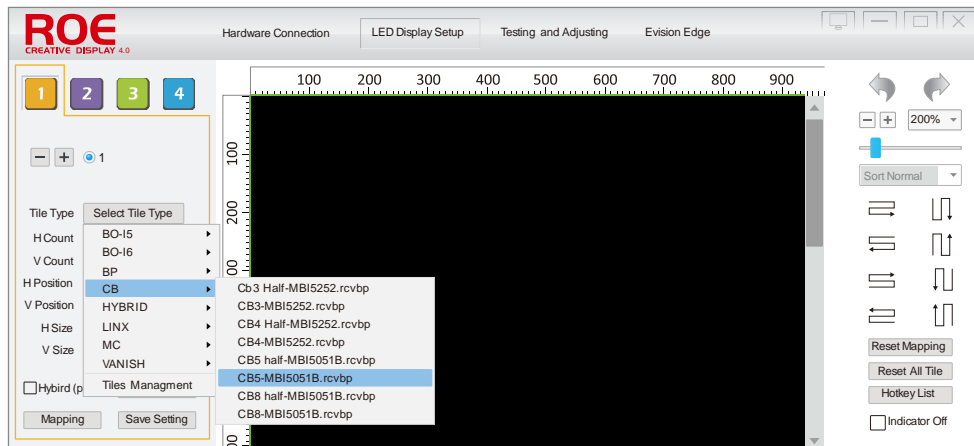

Figure 5-7. Select config file

### 5.8 Adjust Tile QTY and Position

Adjust the QTY of the tiles accordingly. Adjust the position of the tiles, relative to the canvas. The mouse wheel can fast-change the values.

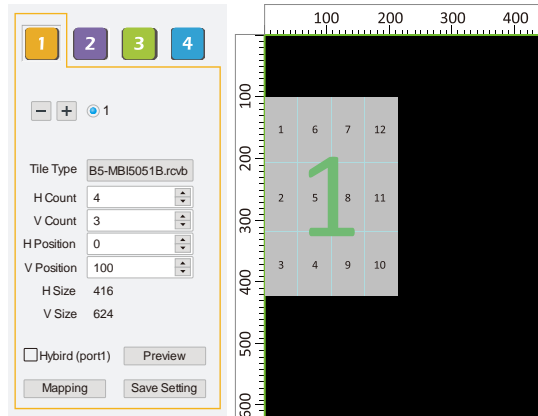

Figure 5-8. Tile QTY and position adjustment

### 5.9 Mapping

Establish the mapping of the tiles accordingly. Use the **Fast Mapping Buttons** for auto-mapping. Left-click on tiles to establish links, while a right-click will remove ones.

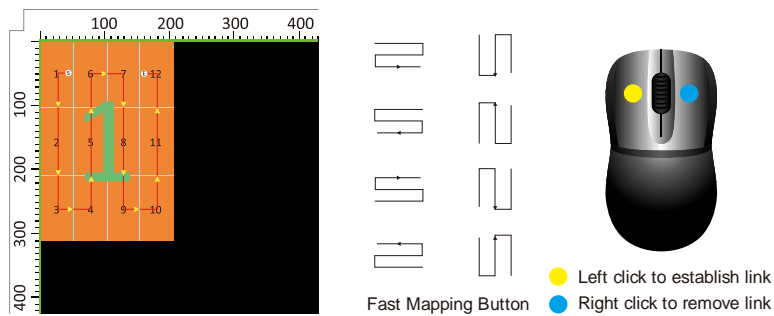

Figure 5-9. Tile mapping

### 5.10 Output Capacity

The outer border of the tiles indicates the output capacity of one output port. RED border indicates that the total resolution of the tiles is exceeding the output capacity.

NOTICE

Please ensure the resolution of tiles to one output port is within capacity.

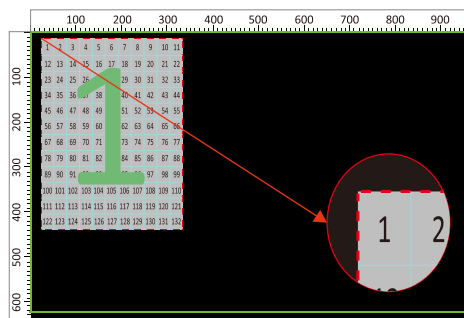

Figure 5-10. Output capacity indicator

### 5.11 Test Patterns

You can use the integrated test function to display patterns on LED to checkout performance and apply adjustments.

Go to **Testing and Adjusting** -> **Test patterns** on EVISION to enable test pattern display.

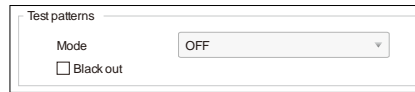

Figure 5-11. EVISION test patterns

Table 5-1. Test pattern presets

Solid color	Red, Green, Blue, White, Black;
Moving lines and grid	HmoveWhite, VmoveWhite, BRMoveWhite, TLMoveWhite, DMoveWhiteCheck;
Gradient color	Gradient Red, Gradient Green, Gradient Blue, Gradient White;
Grey steps	Red Gray Increased, Green Gray Increased, Blue Gray Increased, White Gray Increased;
Others	Alternate Black and White, RGBW Color Bar, Auto-Cycle Test Pattern (10s).

### 5.12 Preview, Save Mapping, Save Setting

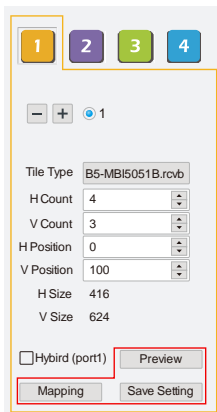

Figure 5-12. Preview, save mapping & setting

Click **Preview** button to send the configuration to LED screens and preview the performance.

Click **Mapping** -> **Save Mapping to Receiver** to upload the mapping configuration to receiver cards.

Click **Save Setting** to upload the configuration to receiver cards, mapping configuration included.

### 5.13 Disconnect PC

Once setup is successfully completed (config saved on processors), PC, as the control source, can be disconnected from the processor. The processor will keep working as configured until changes from control are received.

## 6 Functions

### 6.1 Video Loop

Please be noted that HDCP1.4 is NOT supported on HDMI Loop, but only HDMI In. Please use either DVI In-Loop or HDMI In-Loop.

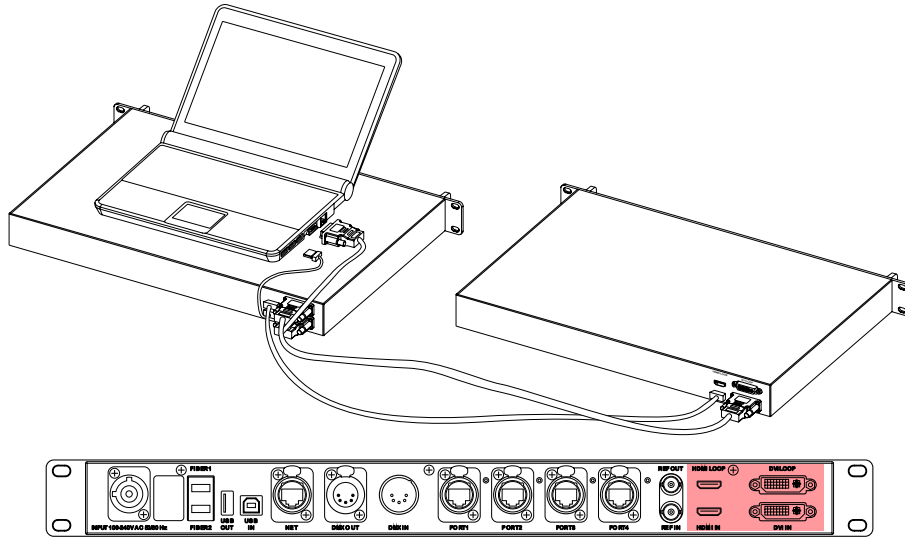

Figure 6-1. HD102 video loop

### 6.2 Multi-function

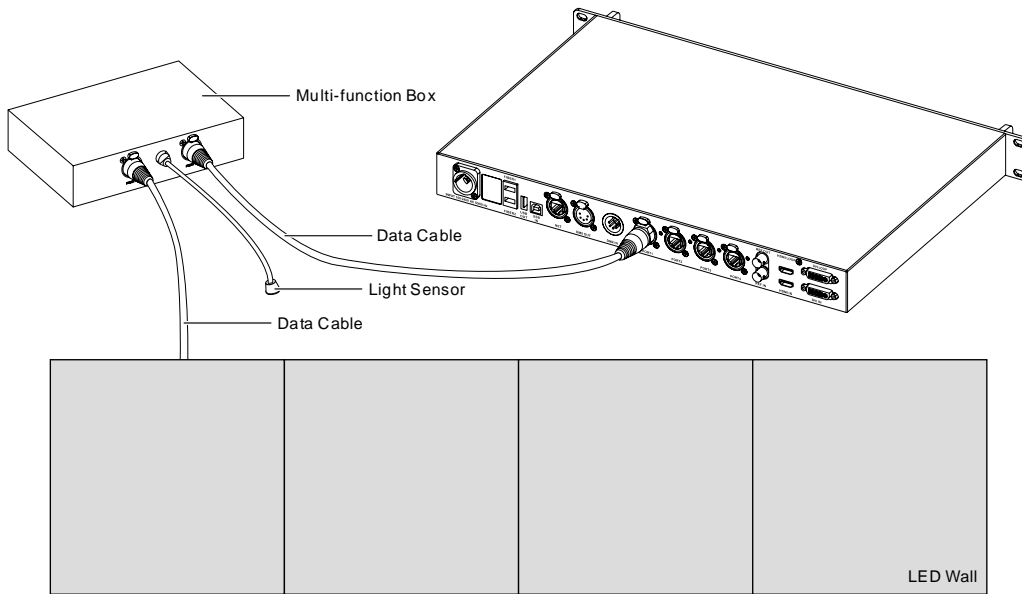

Figure 6-2. HD102 multi-function

### 6.3 Tile Status in EVISION

Table 6-1. Tile status

<b>1</b>	Inactive.	<b>1</b>	Selected. Individual tile positioning will be enabled.
<b>1</b>	Active, configured. The physical tiles will receive corresponding config data when pressing <b>Preview</b> or <b>Save</b> .		Empty (tiles). For special usage like irregular shape LED screen.

### 6.4 Setting Export & Import

Click **Export** button to export the setting as a \*.cfg file for future usage.

Click **Import** button to import a \*.cfg file for fast setup.



Figure 6-3. Export & import setting

### 6.5 Individual Type Positioning

**Individual Type Positioning** provides functions for fast tile identification and position adjusting.

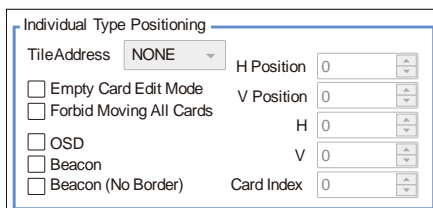

Figure 6-4. Individual type positioning settings

#### 6.5.1 Empty Card Edit Mode

Enabling **Empty Card Edit Mode** will give access to set a tile as an empty one. Left-click to set a tile empty and a click again will undo the action.

Please be noted that once a tile was set to empty, the mapping topology on it will be discarded.

#### 6.5.2 Forbid Moving All Cards

Enabling **Forbid Moving All Cards** will prevent tiles from moving by mouse.

#### 6.5.3 OSD

Enabling **OSD** will display the mapping number of tiles on the LED screen, for fast tile identification.



Figure 6-5. OSD on an LED screen

#### 6.5.4 Beacon

Enabling **Beacon** function will display borders and enable the indicators to blink, in high frequency, of the selected tiles.



Figure 6-6. Beacon function

### 6.5.5 Beacon (No Border)

Enabling **Beacon (No Border)** function will only enable the indicators to blink, in high frequency, of the selected tiles.

## 6.6 Current Gain

### 6.6.1 Light output/contrast

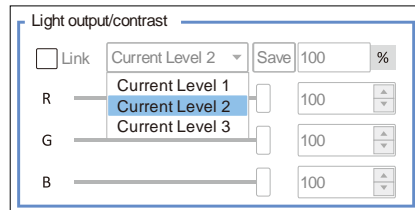

Figure 6-7. Light output profiles and adjustment

## 6.7 Tile Reset

Click **Rest Mapping** button to discard current mapping topology.

Click **Rest All Tile** button to discard all settings/configurations of the tiles, mapping included.

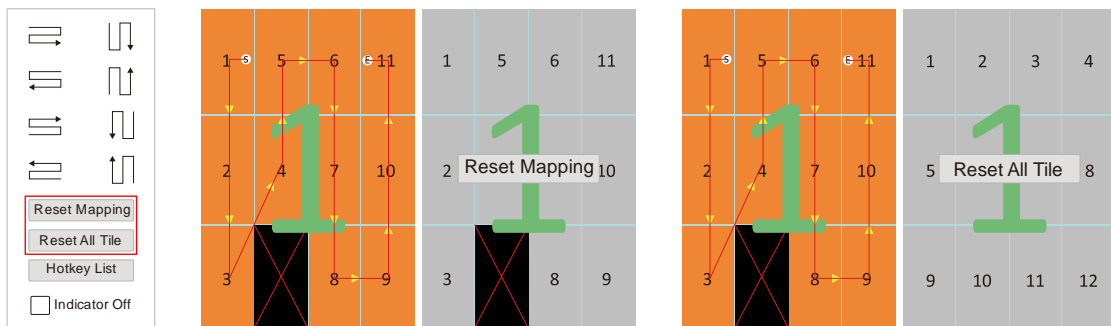

Figure 6-8. Tile mapping reset and tile reset

## 6.8 Advanced Display Settings

### 6.8.1 Grayscale

Click **Manual Adjust** to enable the slider controlling the brightness from 1% to 100%.

Click **Timing Adjust** to enable the time schedule controlling the brightness from 1% to 100%. Need to keep software EVISION running and USB/control Ethernet cable connected.

Click **Auto Adjust** to enable auto-brightness adjustment, multi-function box and light sensor required.

### 6.8.2 Display Color Adjustment

Use the sliders or options to adjust the color temperature of the LED screen.

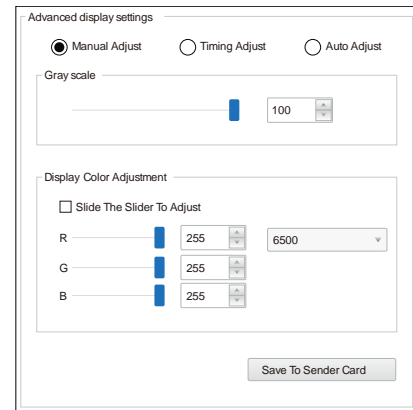

Figure 6-9. Advanced display settings

## 6.9 Extra Functions on Setup

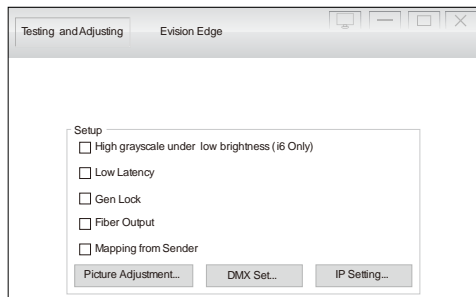

Figure 6-10. Extra functions on setup

### 6.9.1 High Gray Scale Mode

Enabling **High grayscale under low brightness** will improve greyscale when output bright was low. Please be noted that only i6 receiving cards available for this function.

### 6.9.2 Low Latency

Enabling **Low Latency** mode will reduce frame delay from 2 frames to 1 frame, while output width limitation reduced to 512 pixels.

### 6.9.3 Genlock

Enabling the **Genlock** function will provide access for Reference IN & LOOP for generators.

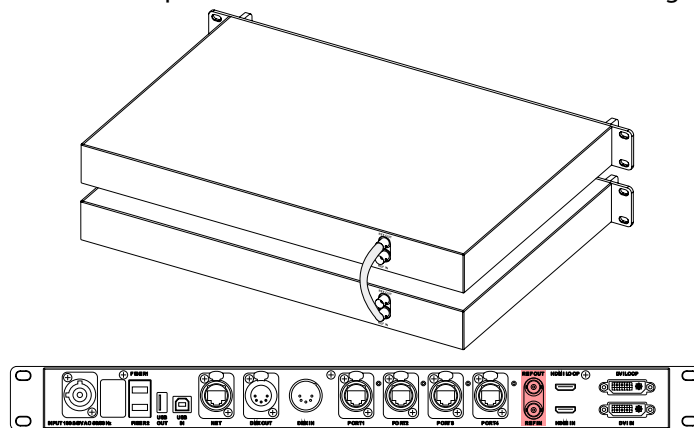

Figure 6-11. HD102 Genlock Loop cabling

### 6.9.4 Fiber Output

Enabling the **Fiber Output** function will access output via fiber output ports. Please be noted that transceiver modules needed.

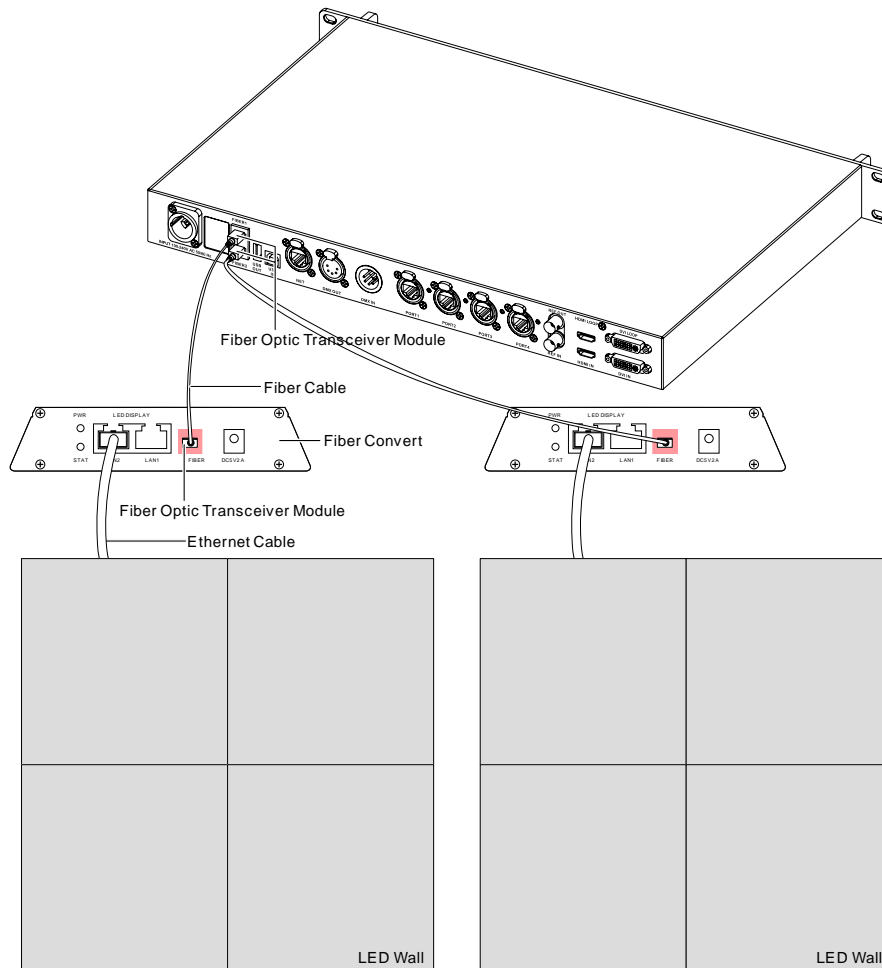

Figure 6-12. HD102 fiber module cabling

### 6.9.5 Mapping from Sender

Enabling **Mapping from Sender** will access mapping data in senders. This will allow no need for re-mapping after swapping tiles on the project side.

### 6.9.6 DMX

Click **DMX Set** to access DMX related settings.

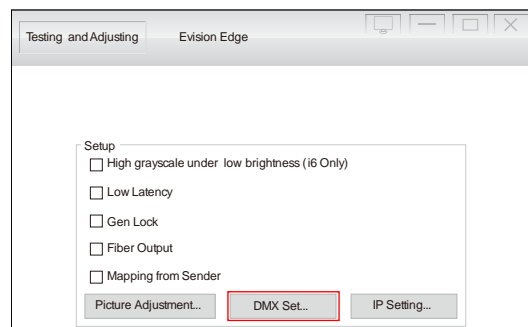

Figure 6-13. DMX setup



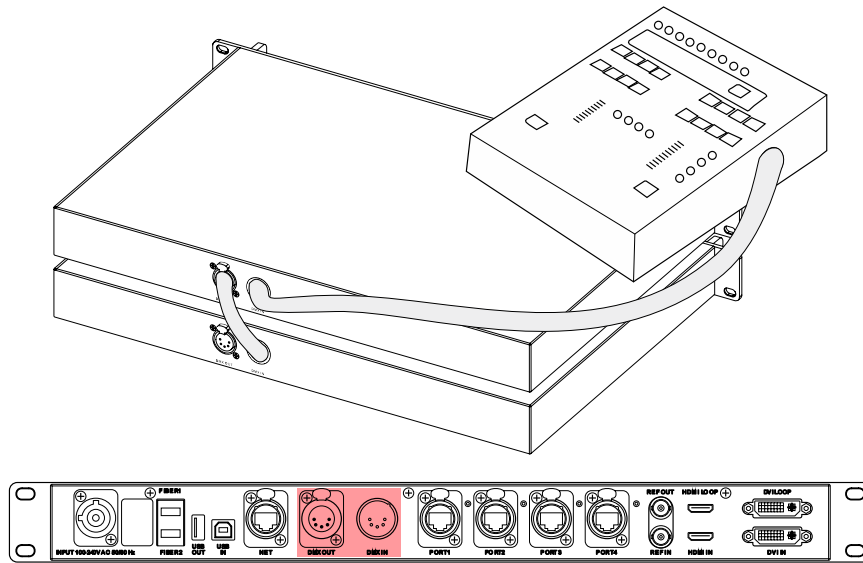

Figure 6-14. HD102 DMX cabling

6.10 HDMI/DVI

Video source switch. Only for HD101.

6.11 EDID Set

**EDID** setup for standard and custom resolutions.

6.12 Import New Tile types

Click **Tile Type** -> **Tiles Management** -> **Add** (Select a series or the root path for import) -> Select \*.rcvp or \*.rcvbp files.

\*.rcvp is specified as the default config file format for import. If trying to import \*.rcvbp files, please specify file type to \*.rcvbp before the file can be selected.

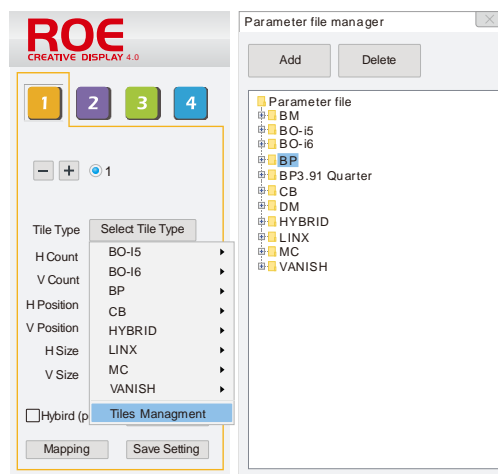

Figure 6-15. Tile import

### 6.13 Hot Backup

HD101 and HD102 both support hot backup, while ONLY HD102 provides the option to specify the Backup Port on control system software.

Create an output data loop from one port to its next, pair port1-port2 or port3-port4 recommended as shown in *Figure 6-16. HD102 hot backup cabling*.

Setup mapping accordingly on both port1 and port2, as shown in *Figure 6-17. Hot Backup using port1 & port2*.

Click **Save Settings** to confirm config, to establish a hot backup data loop.

NOTICE

Please pay attention to the mapping sequence of tiles. If using pair port1-port2, port2 should have the reversed mapping of port1. Apart from the sequence, other settings like type, QTY and location should be the same.

For HD101, disconnect port2 when mapping port1, vice versa. Detailed steps can be referred to below.

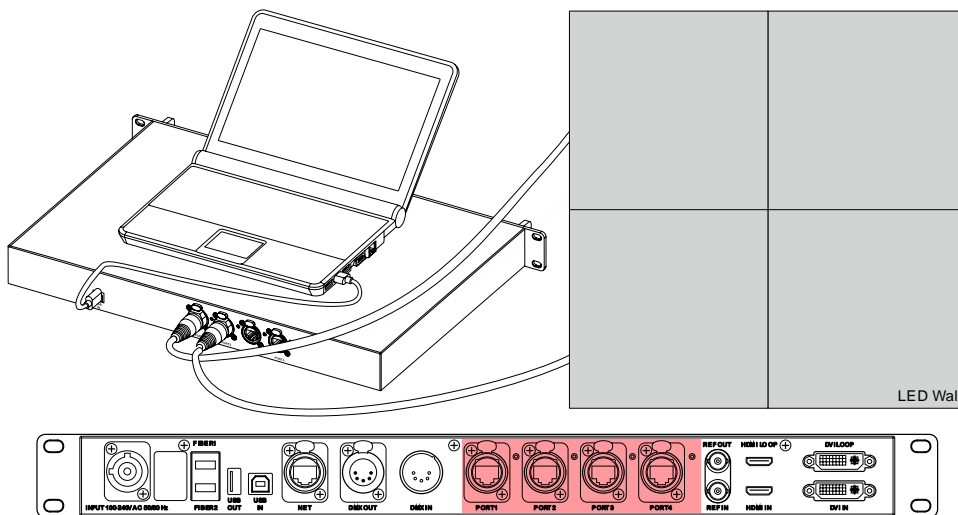

Figure 6-16. HD102 hot backup cabling

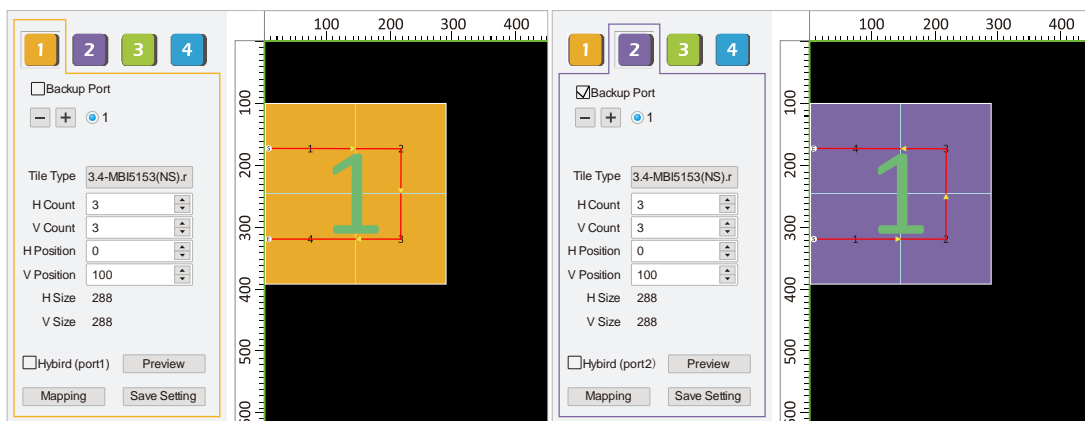

Figure 6-17. Hot Backup using port1 & port2 and port2 as a backup port

### 6.13.1 HD101 Hot Backup Steps

- A. Connect tiles to port1 from tile matrix's beginning, keeping port2 disconnected;
- B. Setup mapping for port1;
- C. Save settings for port1;
- D. Disconnect tiles from port1 and connect tiles to port2 from tile matrix's ending;
- E. Setup mapping for port2;
- F. Save settings for port2;
- G. Reconnect tile to port1, keeping port2 also connected;
- H. Hot backup established.

### 6.13.2 HD102 Hot Backup Steps

- A. Connect tiles to port1 & port2;
- B. Enable *Backup Port* option for port2;
- C. Setup mapping for port 1 & port2;
- D. Save settings for port1 & port2;
- E. Hot backup established.

By enabling the *Backup Port* option, the specific port will be identified as a backup port. In the above case, tiles will switch to port2 (backup port) when port1 (primary port) is down and switch back to port1 (primary) once it is back online.

If not enabled the option, tiles will stay port2 after switching, even port1 is back.

### 6.14 Multiple Processors Control

Use USB In and USB Out to conduct processors/senders in a daisy-chain.

**NOTICE** Maximum 15 processors in daisy-chain supported.

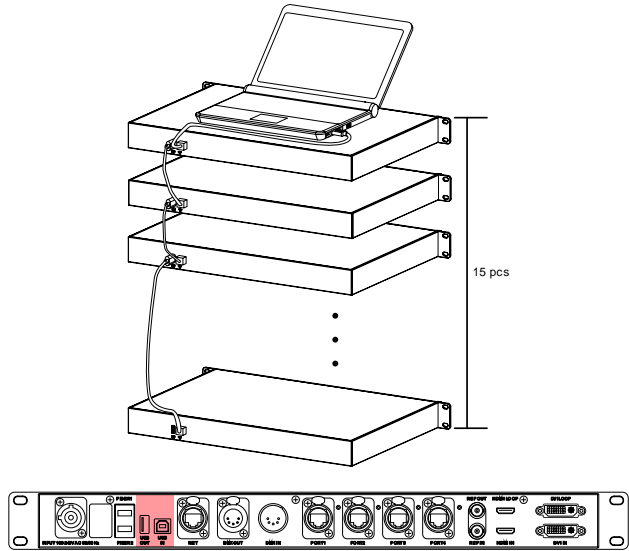

Figure 6-18. Processor cascade cabling

Specify the processor (sender card) you want to set up in **Hardware Connection** page, then apply adjustments in the **LED Display Setup** page.

In the **Testing and Adjusting** page, options will be provided for multiple processors control.

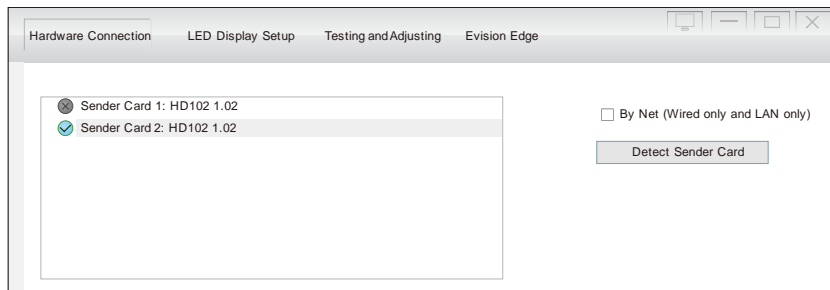

Figure 6-19. Multiple processors control

### 6.15 Multiple Tile Types Control

Recommend to connect different types of tiles to different output ports.

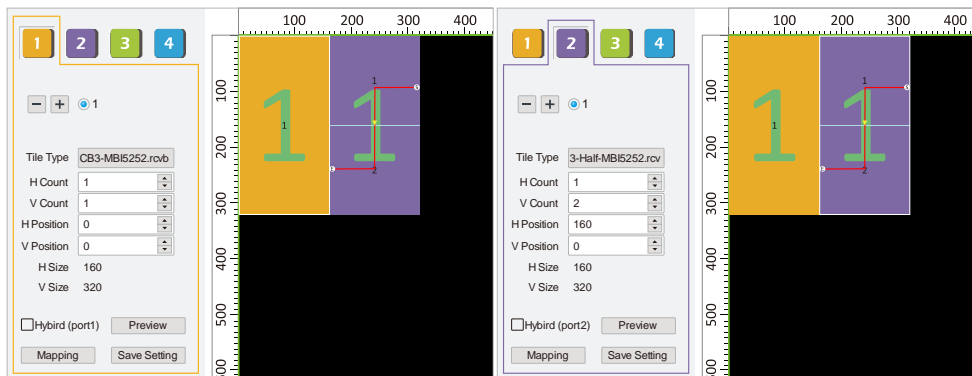

Figure 6-20. Different tiles on different ports

### 6.16 Edge Correction

Edge calibration is a technology to change the brightness of the panel edge pixels, to smoothen the transition of panels. Edge calibration data will NOT overwrite or damage the original calibration data in the module or receiving cards.

Enable **Edge Calibration** and click **Save Setting** before going to **EVISION Edge**.

Click **EVISION Edge** to enter the edge correction function.

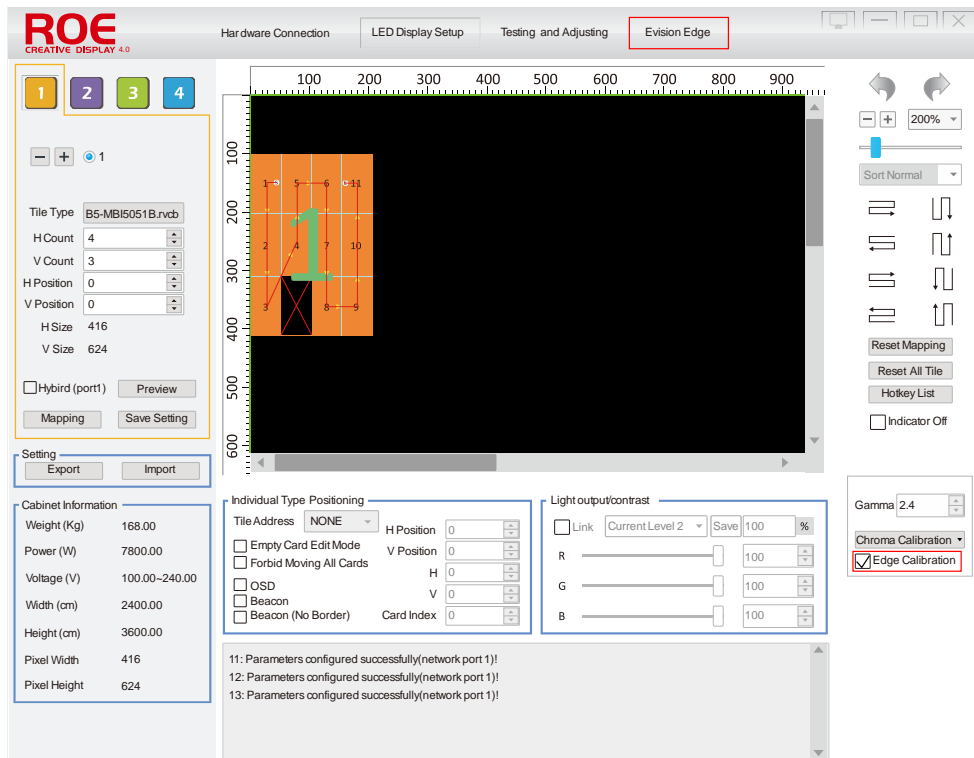

Figure 6-21. Edge correction

#### 6.16.1 Read Screen Information

Click **Read Screen Information** to pull down LED screen setups from all 4 ports of all processors.

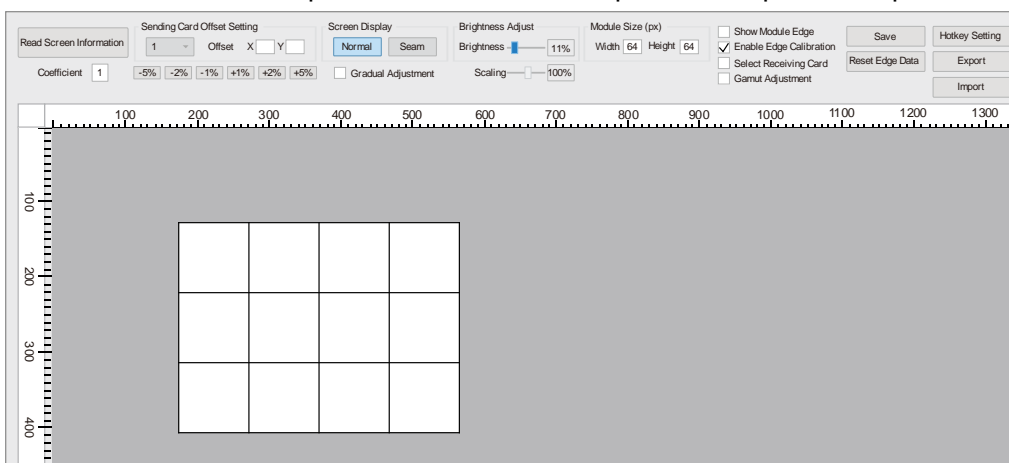

Figure 6-22. Edge correction main window

### 6.16.2 Offset screens from different processors

LED screens from different processors will overlay with each other but be on different layers.

Adjust the **Sending Card Offset Setting** to offset screens so that multi-screens from different processors can be adjusted at the same time.

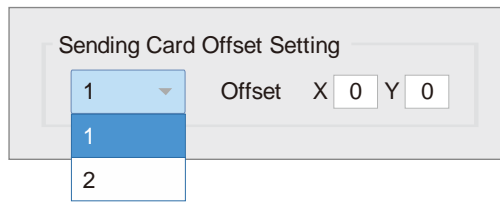

Figure 6-23. Offset screens from different processors

### 6.16.3 Select the edge to adjust the brightness

Select the edge that stands out, either brighter or darker.

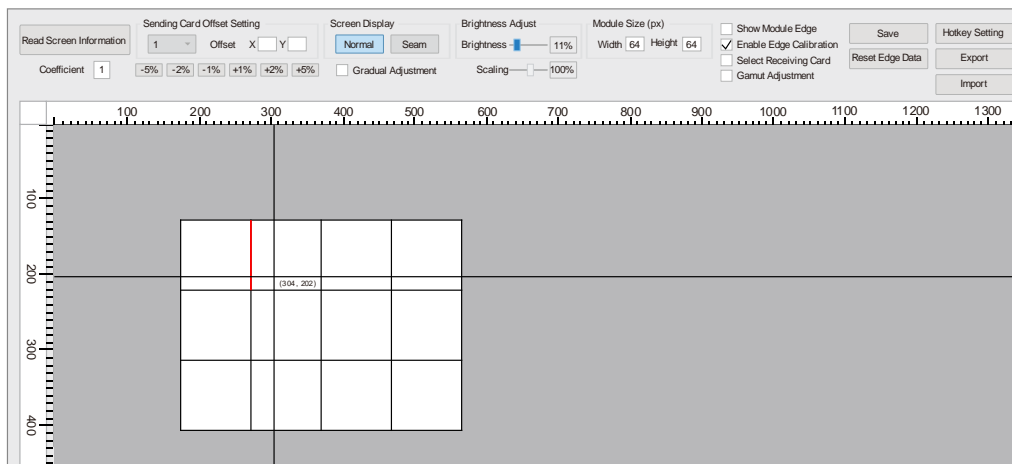

Figure 6-24. Select an edge of panels



Figure 6-25. Bright edge and dark edge on an LED screen

Click on the ruler to select edges.

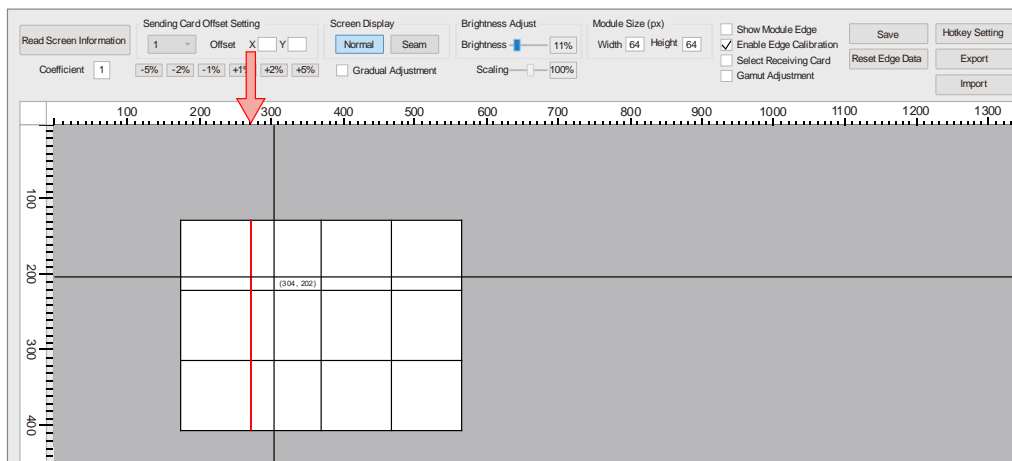

Figure 6-26. Select edges of panels

Check **Show Module Edge** to enable modules edge display for adjustment.

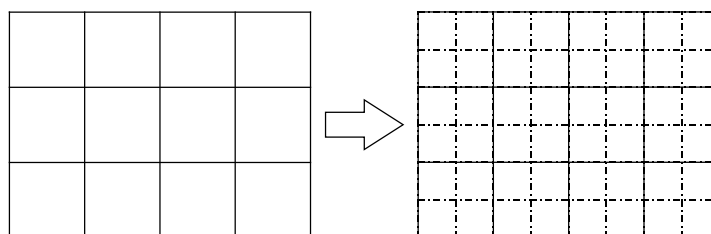

Figure 6-27. Show module edges

### 6.16.4 Adjust the brightness of edges

After edge-selection, use the brightness adjustment buttons or slider to adjust the brightness of the edge pixels, smoothing the transition of panels/modules.

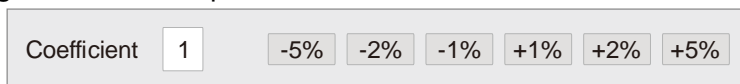

Figure 6-28. Brightness adjustment buttons

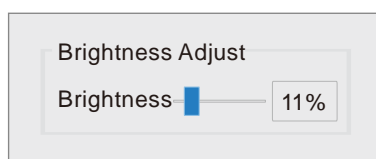

Figure 6-29. Brightness adjustment slider

### 6.17 Gamut Adjustment (Only HD102 supported)

Gamut Adjustment can apply adjustments on the color display of LED screens.

Gamut Adjustment data is separated from the original calibration data, stored on receiving cards. It can apply color display changes without damaging the original calibration data.

#### 6.17.1 Read Screen Information

Click **Read Screen Information** to pull down LED screen setups from all 4 ports of all processors.

#### 6.17.2 Enable Gamut Adjustment mode

Check **Gamut Adjustment** to enable Gamut Adjustment.

### 6.17.3 Set Original Color and Brightness

Select panels to setup original color & brightness data, gathered by a spectrometer like PR655, using the **Set Original Color and Brightness** function.

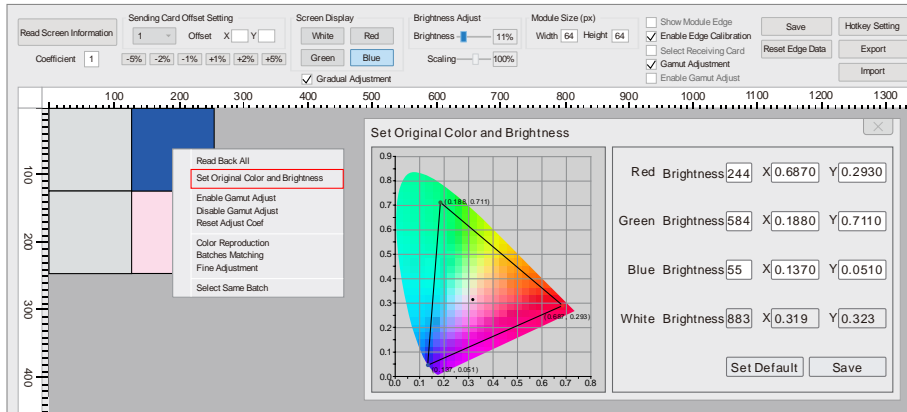

Figure 6-30. Set Original Color and Brightness

### 6.17.4 Batches Matching

After completing the setup for all panels on color & brightness, click **Batches Matching** to initiate calculation to match color space automatically.

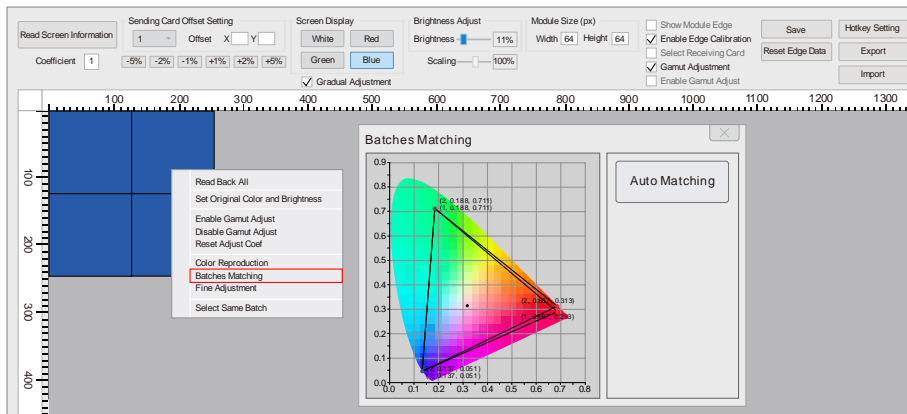

Figure 6-31. Batches Matching

### 6.17.5 Fine Adjustment

Use the **Fine Adjustment** function to apply adjustments manually, covering tolerances introduced by calculation, measurement or instruments like spectrometers.

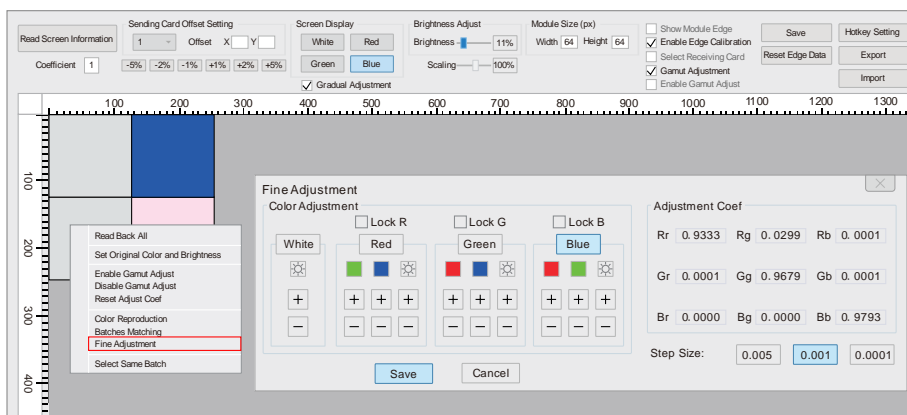

Figure 6-32. Fine Adjustment



### 6.17.6 Color Reproduction

After the setup for original color and brightness, the **Color Reproduction** function will allow the selection of different color space modules, like sRGB, NTSC, PAL, etc., depending on the original color gamut space triangle.

Manual input of Adjustment Coefficients of colors is available.

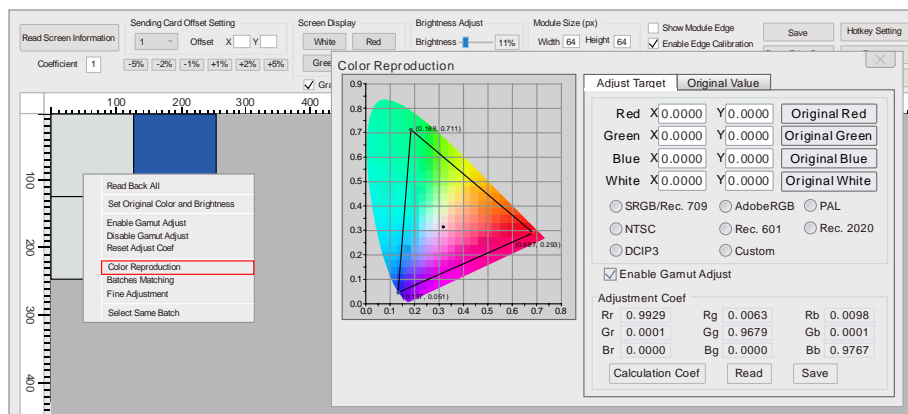

Figure 6-33. Color Reproduction

## 7 Firmware Upgrade for HD102 Processor & Panels

### 7.1 HD102 processor firmware upgrade

7.1.1 Connect PC with the HD102 processor using a USB cable and power on the HD102 processor.



7.1.2 Open LEDUpgrade software.

7.1.3 Select *Send Mode* -> *Sender Mode*.

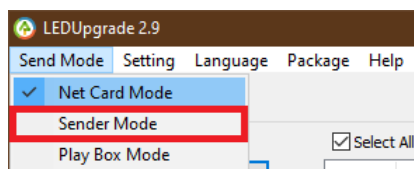

Figure 7-1. LEDUpgrade - Sender Mode

7.1.4 Select the *Sender* tab.

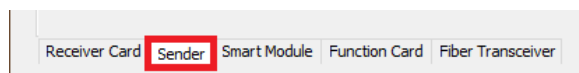

Figure 7-2. Sender tab of LEDUpgrade

7.1.5 Select *Detect Senders*.

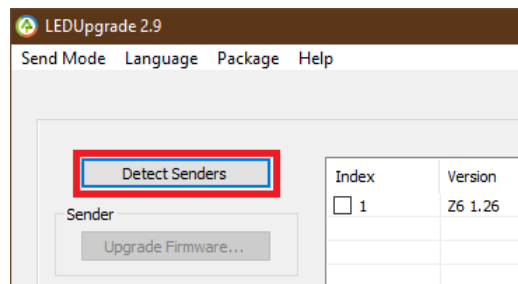

Figure 7-3. Detect senders

7.1.6 Select the processor(s) for firm-ware upgrade.

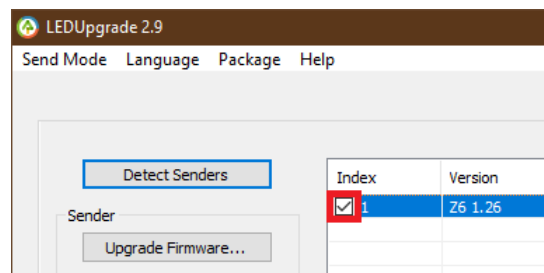

Figure 7-4. Select processor

Receiver Card	Sender	Smart Module	Function Card	Fiber Transceiver
	Main-FPGA1: 1.26	Output Board1: 1.11	Back-FPGA: 1.14	
	Main-FPGA2: 1.10	Output Board2: 1.11	HDMI-FPGA: 1.18	
	Main-ARM: 1.26(1445)	Output Board3: 1.11	HDMI-ARM: 1.16(1336)	
	Front-ARM: 1.26(1438)	Output Board4: 1.11	DVI-FPGA: 1.14	

Figure 7-5. Detailed info on processor firmware

7.1.7 Select a firmware file or preset for the upgrade.

You can either browse desired firmware for the upgrade or preset one.

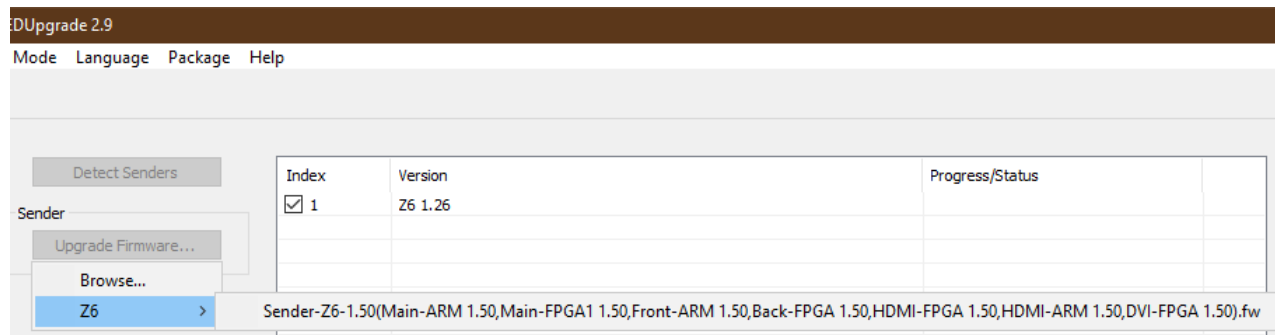

Figure 7-6. Browse firmware

7.1.8 Processor firmware upgrade completed

Wait for the upgrade completion notification and the upgrade is completed.

7.2 Panel firmware upgrade

7.2.1 Select Sender Mode if panels connecting to the processor.

Select Net Card Mode if panels connecting to the PC.

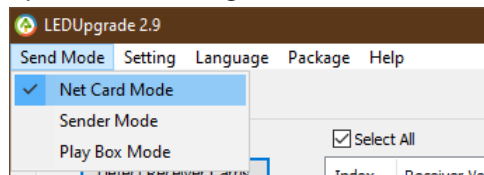

Figure 7-7. Net Card Mode

7.2.2 Select the Receiver Card tab.

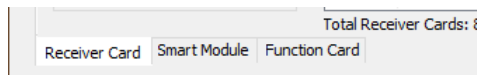

Figure 7-8. Receiver Card Mode

7.2.3 Select panel(s) for upgrade

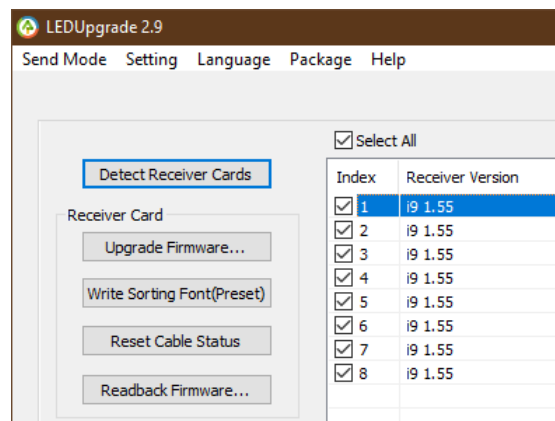

Figure 7-9. Select panels

7.2.4 Select panel firmware for upgrade

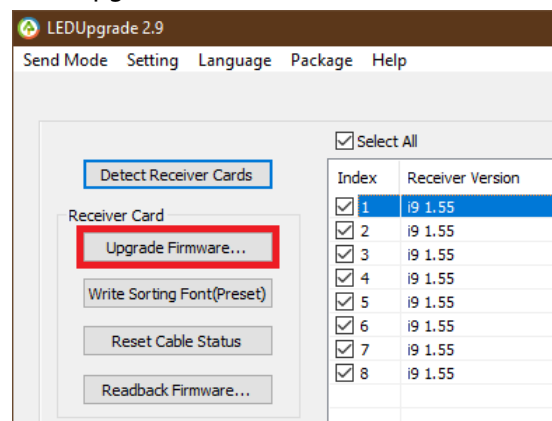

Figure 7-10. Browse firmware

7.2.5 Panel firmware upgrade completed

Wait for the upgrade completion notification and the upgrade is completed.

## 8 Troubleshooting

8.1 No sender detected while using Ethernet cable for control

8.1.1 Cables are not correctly connected.

Check the Ethernet cable for control and connect it again,

8.1.2 IP setup unsuccessful

Please refer to page [39, 9.3 IP Setup](#) to complete IP settings.

8.2 LED screens didn't show the changes made on EVISION.

Please use **Preview** or **Save Setting** buttons to push changes up to the LED screens.

## 9 Appendix

### 9.1 Accessories for HD102

#### 9.1.1 Fiber Optic Transceiver Modules

##### 9.1.1.1 Device Picture



Figure 9-1. Fiber optic transceiver module picture

##### 9.1.1.2 Specification

Table 9-1. Specification of CLT-SFP-2F fiber optic transceiver module

Item	Figure
Module	CLT-SFP-2F
Storage Temperature	-40~85°C
Operating Temperature	0~70°C
Voltage Supply	3.0~3.6V
Data Rate	2.5Gb/s
Mode	Single-mode
Distributed Feedback Laser	DFB-LD
Fiber Connector	Duplex LC
Transmission Distance	5km

#### 9.1.2 Fiber Converter

##### 9.1.2.1 Device Picture



Figure 9-2. Fiber converter

Table 9-2. Table of the interfaces of H2F fiber converter

Item	Figure
PWR & STAT Indicators	PWR light (RED) indicates power, blinking or on. STAT light (Green) indicates working status.
LAN2 & LAN1 ports – LED DISPLAY	Input/output ports, Gigabit Ethernet signals.
FIBER ports	Input/output port, fiber optic signals.
DC5V2A port	DC power supply

9.1.2.2 Specification

Table 9-3. Specification of H2F fiber converter

Item	Figure
Module	H2F
Storage Temperature	-40~85°C
Operating Temperature	0~70°C
Voltage Supply	5V 2A DC
Dimension	L128.5 x W99.6 x 28.3 mm
Data Rate	2.5Gb/s
Mode	Single-mode
Distributed Feedback Laser	DFB
Fiber Connector	Duplex LC
Transmission Distance	15km
Fiber Interface	1port, 2.5G
Gigabit Ethernet Port	LAN1 & LAN2 (RJ45)

9.1.3 Multi-function Card

9.1.3.1 Device Picture

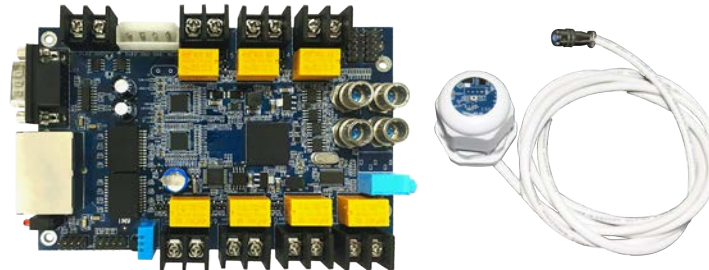

Figure 9-3. Multi-function card & brightness sensor

9.1.3.2 Specification

Table 9-4. Specification of iM9 multi-function card

Item	Figure
Module	iM9 Multi-function Card
Voltage Supply	3.3~6.0V
Power	4.65W
Receiving Card Supported	5A, i5A, i6
Transmission Equipment	Gigabit network switch and fiber converter supported
Switches for Remote Power Management	4 switches for LED display; 2 switches for air conditioner and fans; 1 switch for other application
Brightness Adjustment	Output brightness can automatically adjust to the environment.
Sensors	Temperature, humidity, smoke

### 9.2 Keyboard Shortcuts

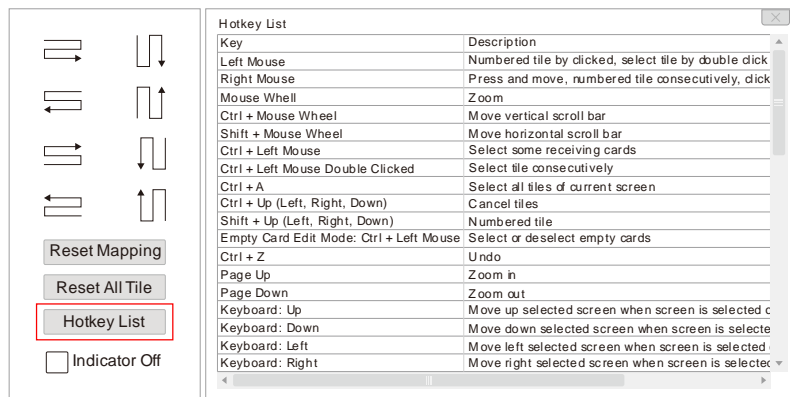

Figure 9-4. Keyboard shortcuts for EVISION

### 9.3 IP Setup

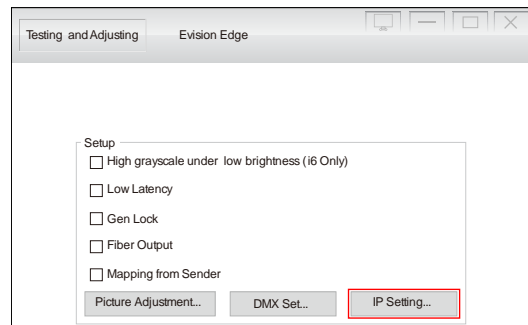

Figure 9-5. IP setting

Go to **Testing and Adjusting** -> **Setup** -> **IP Setting...** in EVISION to enable DHCP, allowing Processor HD102 to offer an IP address to PC automatically, or to set up a static IP address for the processor.

If keeping DHCP disabled, static IP address and netmask need to be set up for PC.

Make sure the processor and PC are located in the same LAN (local area network). For example, processor is using 192.168.1.100/24 (IP address: 192.168.1.100, netmask: 255.255.255.0), and PC can go with 192.168.1.123/24 (IP address: 192.168.1.123, netmask: 255.255.255.0).

For win10, you can go through the below procedures to change IP settings.

**Setting** -> **Network & Internet** -> **Change adapter options** -> **Ethernet** (double click) -> **Internet Protocol Version 4 (TCP/IPv4)** (double click) -> **Use the following IP address** (key in IP address and subnet mask) -> **OK**.

## 9.4 Maximum Loading Capacity of One Output Port of HD102

Table 9-5. Maximum loading of one output port of HD102

Refresh Rate Product	60Hz	50Hz
BO2 (176 x 176 px)	17 pcs	20 pcs
BO3 (144 x 144 px)	25 pcs	30 pcs
BP3 (128 x 128 px)	32 pcs	38 pcs
BP5 (96 x 96 px)	57 pcs	68 pcs
MC5H (104 x 104 px)	49 pcs	58 pcs
MC7H (80 x 80 px)	82 pcs	98 pcs
MC9H	129 pcs	154 pcs
MC12H	230 pcs	276 pcs
MC18H	512 pcs	512 pcs
HY15	164 pcs	196 pcs
HY15S	512 pcs	512 pcs
HY18	256 pcs	307 pcs
CB5	24 pcs	28 pcs
CB8	50 pcs	60 pcs
BM7	82 pcs	98 pcs
BM15	164 pcs	196 pcs



9.5 Menu Topology of HD102

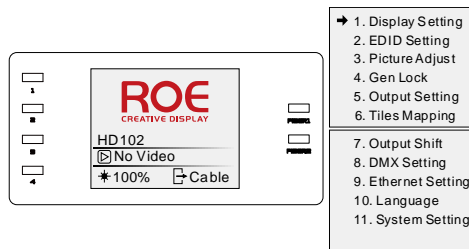

Figure 9-6. HD102 main menu

<p>1. Display Setting</p> <ul style="list-style-type: none"> <li>1. Brightness                     <ul style="list-style-type: none"> <li>Brightness 100%</li> </ul> </li> <li>2. CCT                     <ul style="list-style-type: none"> <li>1. CCT 6500</li> <li>2. Default</li> </ul> </li> <li>3. Black (o )</li> <li>4. Better Grey (o )</li> <li>5. Test Mode                     <ul style="list-style-type: none"> <li>1. Normal</li> <li>2. Red</li> <li>3. Green</li> <li>4. Blue</li> <li>5. White</li> <li>6. Vertical Line</li> <li>7. Horizontal Line</li> <li>8. Left Slash</li> <li>9. Right Slash</li> <li>10. Pane</li> <li>11. Gradient Red</li> <li>12. Gradient Green</li> <li>13. Gradient Blue</li> <li>14. Gradient White</li> <li>15. Black</li> </ul> </li> </ul>	<p>3. Picture Adjust</p> <ul style="list-style-type: none"> <li>1. Enable (o )</li> <li>2. Hue 0</li> <li>3. Saturation 100</li> <li>4. Compensating 0</li> <li>5. Contrast 100</li> <li>6. Save</li> <li>7. Reset</li> </ul> <hr/> <p>4. Gen Lock (o )</p> <hr/> <p>5. Output Setting</p> <ul style="list-style-type: none"> <li>1. Fiber/Cable                     <ul style="list-style-type: none"> <li>1. By Cable (o )</li> <li>Output Mode: By Cable</li> <li>2. By Fiber ( o )</li> <li>Output Mode: By Fiber</li> </ul> </li> </ul> <hr/> <p>6. Tiles Mapping</p> <ul style="list-style-type: none"> <li>1. Mapping Source                     <ul style="list-style-type: none"> <li>1. Sender</li> <li>2. Receiver</li> </ul> </li> <li>V</li> <li>1. Mapping Source                     <ul style="list-style-type: none"> <li>1. Sender</li> <li>2. Receiver</li> </ul> </li> <li>V</li> </ul>	<p>7. Output Shift</p> <ul style="list-style-type: none"> <li>1. Port 1</li> <li>2. Tile Width 128</li> <li>3. Tile Height 128</li> <li>4. Column 1</li> <li>5. Row 1</li> <li>6. X Offset 0</li> <li>7. Y Offset 0</li> <li>8. Link Type M</li> <li>9. Save</li> </ul> <hr/> <p>8. DMX Setting</p> <ul style="list-style-type: none"> <li>1. Date Setting</li> <li>2. Time Setting</li> <li>3. Factory Reset</li> <li>4. Version</li> </ul> <hr/> <p>9. Ethernet Setting</p> <ul style="list-style-type: none"> <li>1. DHCP (o )</li> <li>2. Static IP</li> <li>IP: 192.168.1.100</li> </ul> <hr/> <p>10. Language</p> <ul style="list-style-type: none"> <li>1. Chinese</li> <li>2. English</li> </ul> <hr/> <p>11. System Setting</p> <ul style="list-style-type: none"> <li>1. Date Setting</li> <li>2. Time Setting</li> <li>3. Factory Reset</li> <li>4. Version</li> </ul>
<p>2. EDID Setting</p> <ul style="list-style-type: none"> <li>1. 800 x 600</li> <li>2. 1024 x 768</li> <li>3. 1280 x 720</li> <li>4. 1280 x 960</li> <li>5. 1280 x 1024</li> <li>6. 1366 x 768</li> <li>7. 1440 x 900</li> <li>8. 1440 x 1050</li> <li>9. 1600 x 900</li> <li>10. 1920 x 1080</li> <li>11. 2048 x 1024</li> <li>12. Custom</li> </ul>		